

RoHS

Client approval			Hongli approval		
					
			陈	钟云	

/ 020-86733333

/ 020-86733883 86733938 86733265

/

- 1.
- 2.
- 3.

HL-AF-5060H271BU46FU79GC-S1-T1

Features

-
- SMT
-
- Level 4
- 1000PCS
- RoHS



ATTENTION

Package Dimensions

Applications

LCD

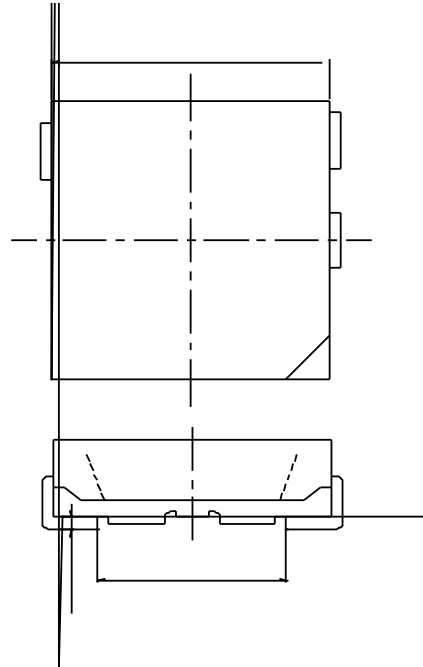

Recommended Soldering Pattern

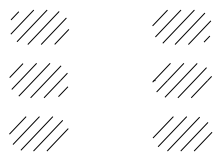

±0.15mm

HL-AF-5060H271BU46FU79GC-S1-T1

Selection Guide

1. 0
 0 1/2

Electrical / Optical Characteristics at Ta=25°C

Absolute Maximum Ratings at Ta=25°C

0.1ms 1/10 ± . ± . ±

HL-AF-5060H271BU46FU79GC-S1-T1

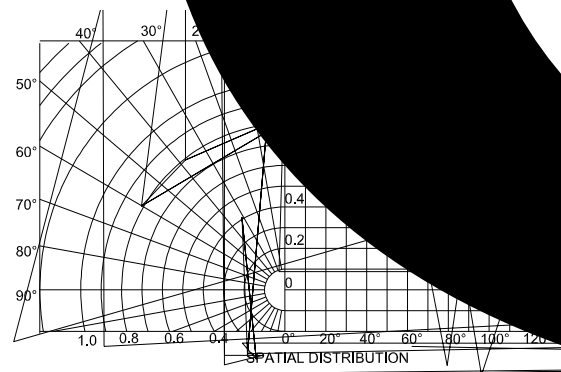

HL-AF-5060H271BU46FU79GC-S1-T1

Bin Range of Chromaticity Coordinate Bin

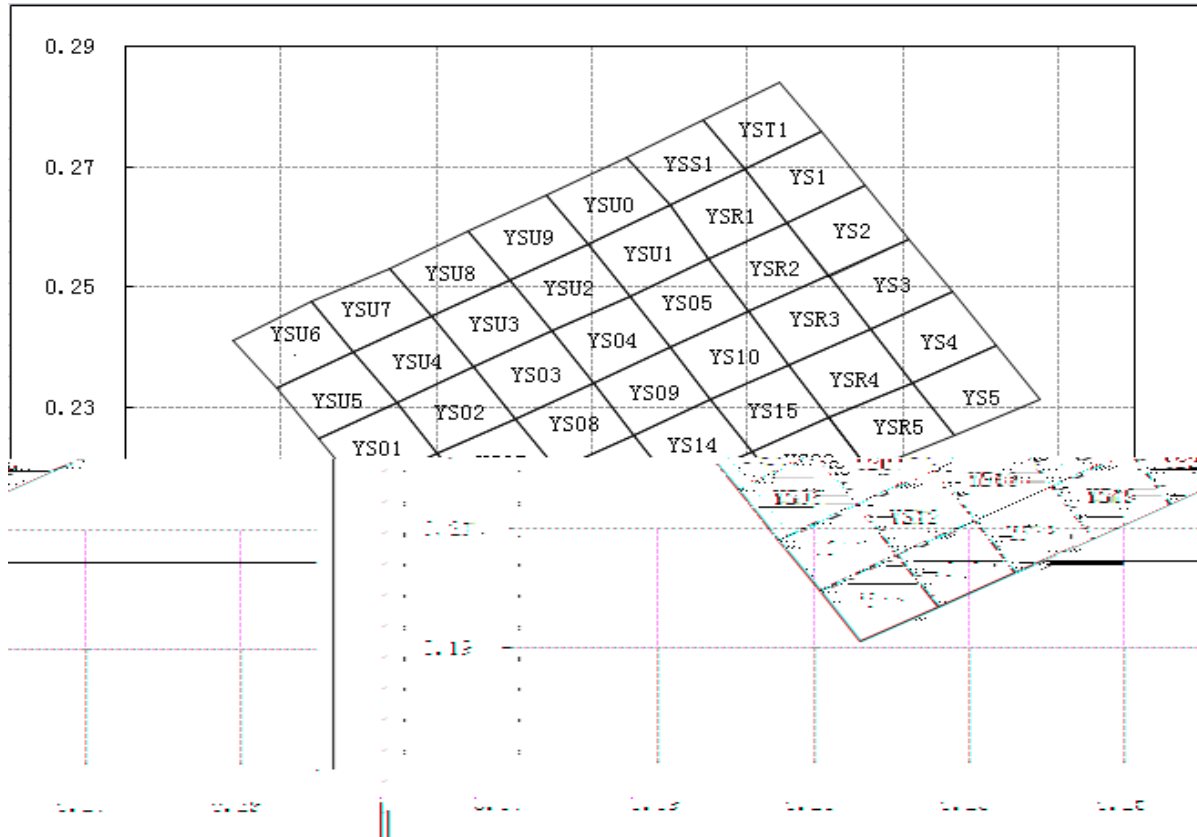

YS01	0.1948	0.2248	YS07	0.2102	0.2223	YS13	0.2255	0.2197
	0.2002	0.2164		0.2155	0.2139		0.2307	0.2112
	0.2102	0.2223		0.2255	0.2197		0.2407	0.2170
0.2354	0.2255	YS02	0.2049	0.2308	YS08	0.2202	0.2282	YS14
0.2407	0.2170		0.2102	0.2223		0.2255	0.2197	
0.2506	0.2227		0.2202	0.2282		0.2354	0.2255	
0.2454	0.2313	YS03	0.2149	0.2367	YS09	0.2302	0.2341	YS15
0.2454	0.2313		0.2149	0.2367		0.2302	0.2341	
0.2506	0.2227		0.2202	0.2282		0.2354	0.2255	
0.2606	0.2285	YS04	0.2302	0.2341	YS10	0.2454	0.2313	YS16
0.2554	0.2372		0.2250	0.2427		0.2402	0.2400	
0.2108	0.1997		0.2250	0.2427		0.2402	0.2400	
0.2161	0.1913	YS05	0.2302	0.2341	YS11	0.2454	0.2313	YS17
0.2261	0.1970		0.2402	0.2400		0.2554	0.2372	
0.2208	0.2055		0.2350	0.2486		0.2503	0.2459	
0.2208	0.2055	YS06	0.2350	0.2486	YS12	0.2055	0.2080	YS18
0.2261	0.1970		0.2402	0.2400		0.2108	0.1997	
0.2360	0.2027		0.2503	0.2459		0.2208	0.2055	
0.2307	0.2112	YS06	0.2451	0.2546	YS12	0.2155	0.2139	YS18
0.2307	0.2112		0.2002	0.2164		0.2155	0.2139	
0.2360	0.2027		0.2055	0.2080		0.2208	0.2055	
0.2459	0.2084	YS06	0.2155	0.2139	YS12	0.2307	0.2112	YS18
0.2407	0.2170		0.2102	0.2223		0.2255	0.2197	

HL-AF-5060H271BU46FU79GC-S1-T1

Reliability Test Items And Conditions

Failure Criteria

Luminous Flux				

...

...

*

HL-AF-5060H271BU46FU79GC-S1-T1

SMT Reflow Soldering Instructions SMT

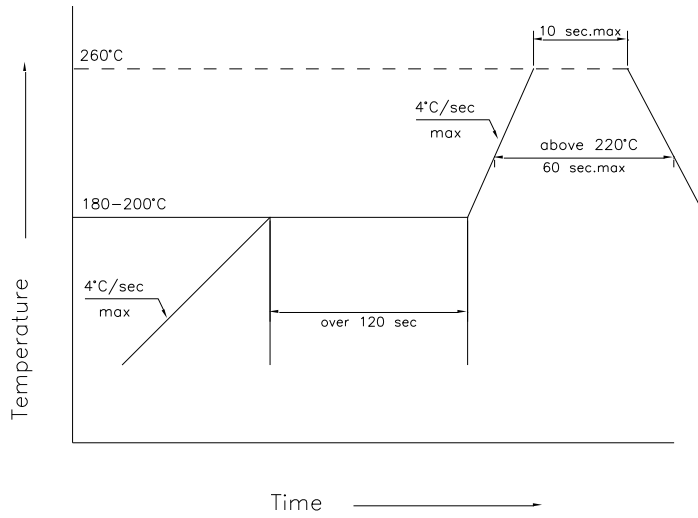

Soldering iron

300°C 3

Repairing

LED
LED

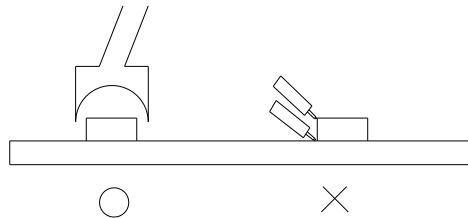

Cautions

LED LED LED

LED

LED

100PPM

LED

LED

LED

900PPM

LED

LED

LED

1500PPM

900PPM

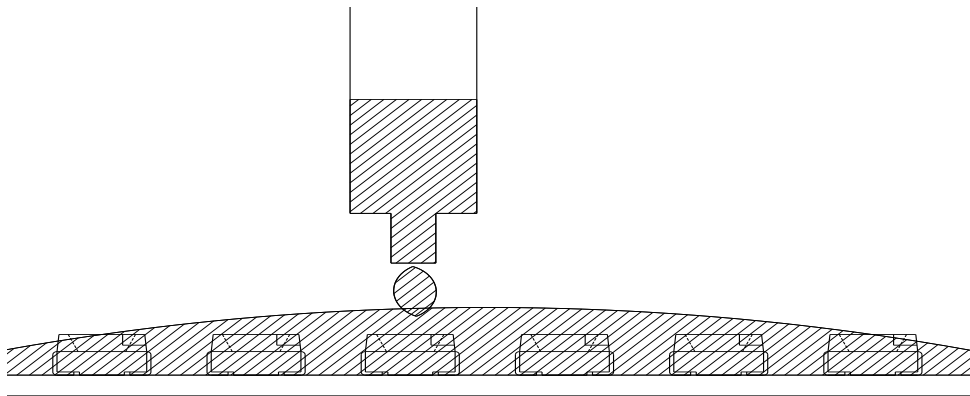

LED

HL-AF-5060H271BU46FU79GC-S1-T1

Label

Φ

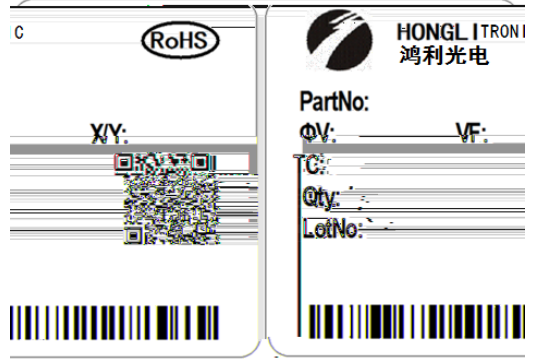

Tape Specifications (Units : mm)

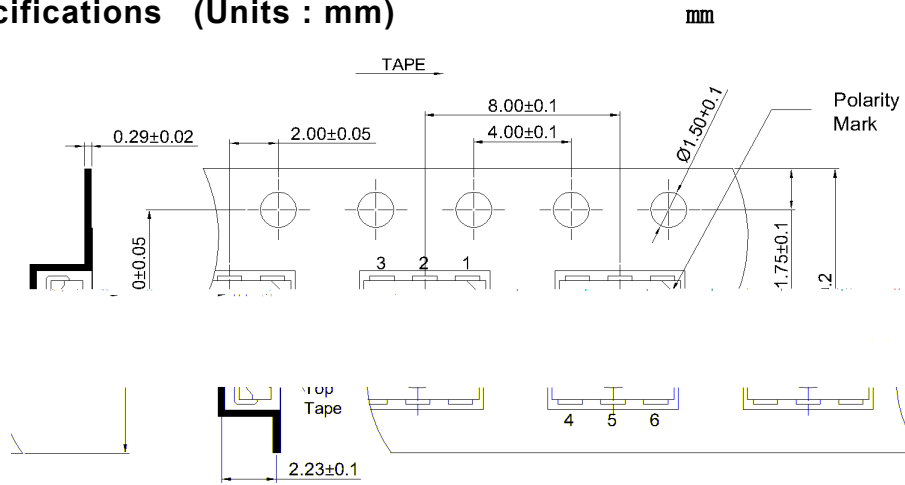

Reel Dimensions

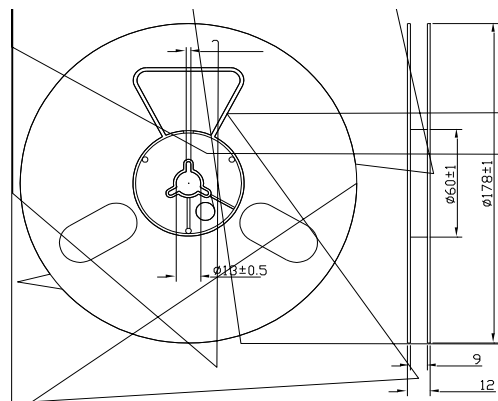

Moisture Resistant Packaging

