

HVR-3528DES

3528 PLCC4

Products Series

High luminous efficiency, consistency, stability and reliability, it is mainly used in automobile applications.

- PPA
- 50% I_v 120
- 625nm
- AEC-Q102 & IEC 60810

Features

- Package Colorless clear silicone in white PPA cup
- Viewing angle at 50% I_v: 120
- Color: Red (625nm)
- Qualifications: Passed reliability test per AEC-Q102 & IEC 60810 requirement



Ordering Information

Type	Luminous Intensity I _v @ I _f =50mA	Ordering Code
HVR-3528DES - XXXX - X - XXXX Brightness Color Forward Voltage	1.40 - 3.55 cd	XXXXXX



HVR-3528DES-ABCA-1-XXXX

4

AB BA BB CA



4



HVR-3528DES-XXXX-1-3A4B

4

3A 3B 4A 4B

Note

■ Brightness Grouping

Only one brightness group will be packed in one reel. Please refer to page #4 for details.
E.g.: HVR-3528DES-ABCA-1-XXXX, means only one bin of AB, BA, BB or CA is in one reel.

■ Color Grouping

Please refer to page #4 for details.

■ Forward Voltage Groups

Only one forward voltage group will be packed in one reel. Please refer to page #4 for details.

E.g.: HVR-3528DES-XXXX-1-3A4B, means only one bin of 3A, 3B, 4A or 4B is in one reel.

Maximum Ratings

Parameters Symbol

Characteristics (T_s $f = 50 \text{ mA}$)

Parameters		Symbol	Rating	Unit
Wavelength at Peak Emission	typ.	λ_{peak}	634	nm
Dominant Wavelength	min.	λ_{dom}	620	nm
	typ.	λ_{dom}	625	nm
	max.	λ_{dom}	630	nm
Spectral Bandwidth at 50% I_{rel} max	typ.		19	nm
50 % I_v Viewing Angle at 50 % I_v	typ.		120	
Forward Voltage	min.	V_f	1.90	V
	typ.	V_f	2.15	V
	max	V_f	2.50	V
Reverse Current ($V_R=12V$)	typ.	I_r	0.2	μA
	max.	I_r	10	μA
PN - Real Thermal Resistance (Junction / Ambient)	max.	$R_{th JA_{real}}$	300	K/W
PN - Real Thermal Resistance (Junction / Solder Point)	max.	$R_{th JS_{real}}$	130	K/W

Brightness Grouping (T_s $f = 50$ mA)

Grouping	Luminous Intensity I_v min.	Luminous Intensity I_v max.	Luminous Flux Φ_v typ.
AB	1.40 cd	1.80 cd	4.80 lm
BA	1.80 cd	2.24 cd	6.10 lm
BB	2.24 cd	2.80 cd	7.60 lm
CA	2.80 cd	3.55 cd	9.50 lm

Forward Voltage Grouping (T_s $f = 50$ mA)

Grouping	Forward Voltage V_f min.	Forward Voltage V_f max.
3A	1.90 V	2.05 V
3B	2.05 V	2.20 V
4A	2.20 V	2.35 V
4B	2.35 V	2.50 V

Dominant Wavelength Grouping (T_s $f = 50$ mA)

Grouping	Dominant Wavelength λ_{dom} min.	Dominant Wavelength λ_{dom} max.
1	620 nm	630 nm

Information on Label

E.g. BA-1-3A

Brightness	Color	Forward Voltage
BA	1	3A

$$- V(\lambda) =$$

Relative Spectral Emission - $V(\lambda)$ = Standard Eye Response Curve

$$I_{rel} = f(\lambda); T_s \quad I_f = 50 \text{ mA}$$

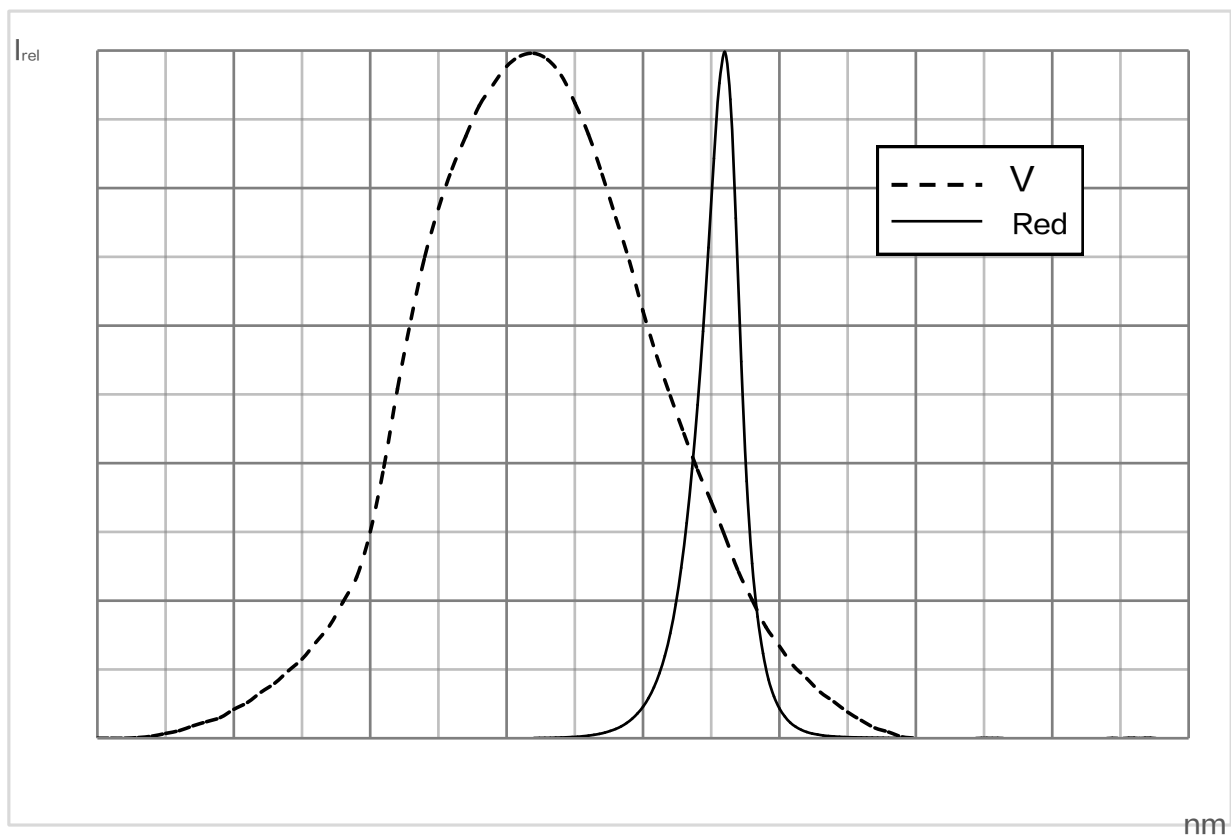

Radiation Characteristics

$I_{rel} = f(\theta) \quad T_s = 25$

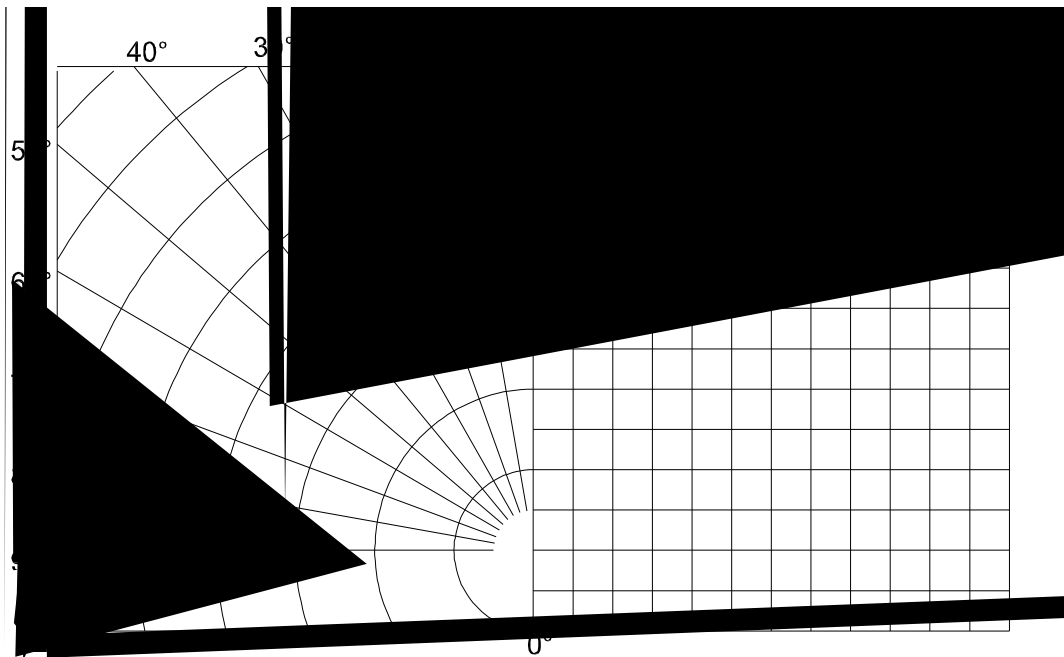

Forward Current

$I_f = f(V_f); T_a$

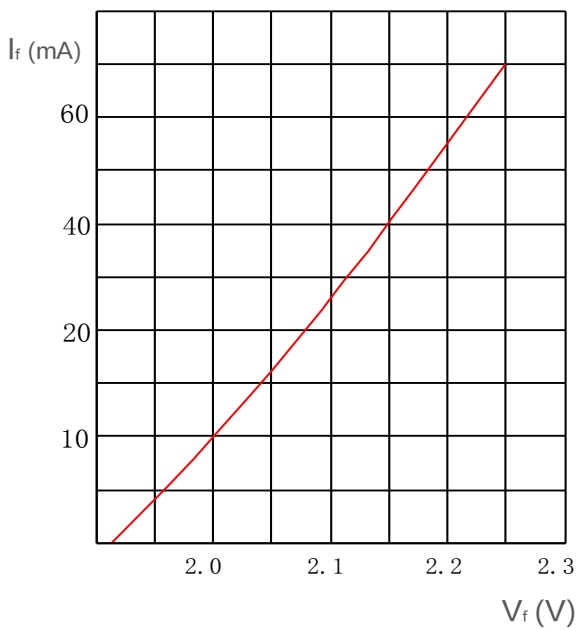

Relative Luminous Intensity

$I_v/I_v(50\text{mA}) = f(I_f); T_a$

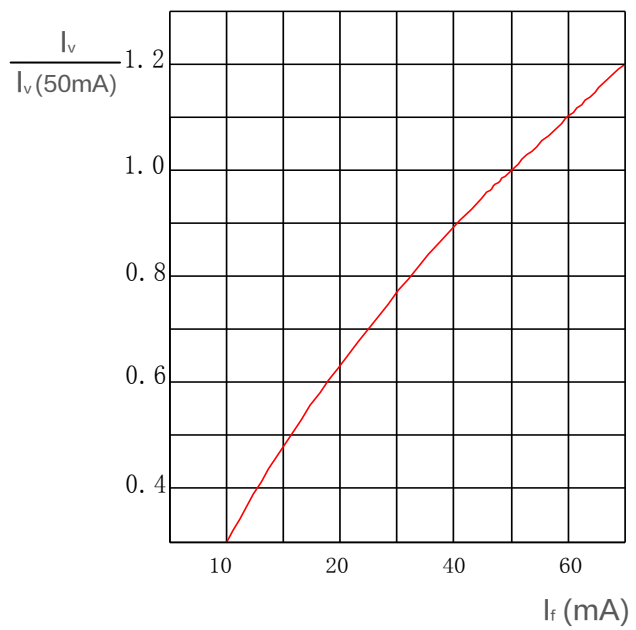

Relative Forward Voltage

$V_f = V_f - V_f$; $I_f = 50 \text{ mA}$

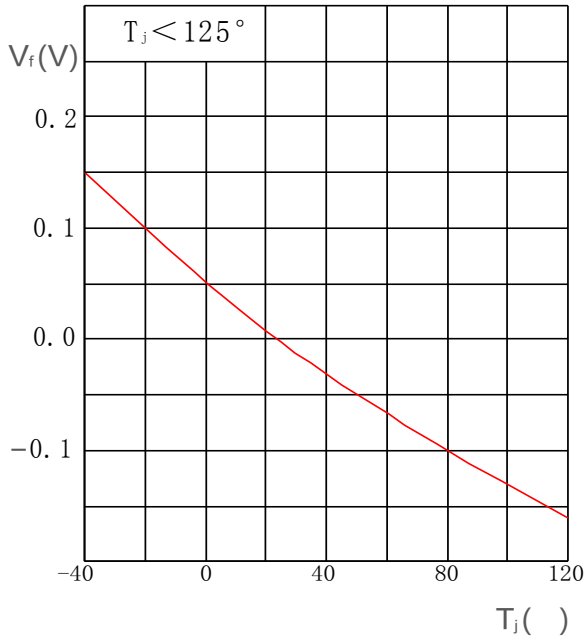

Relative Luminous Intensity

I_v/I_v ; $I_f = 50 \text{ mA}$

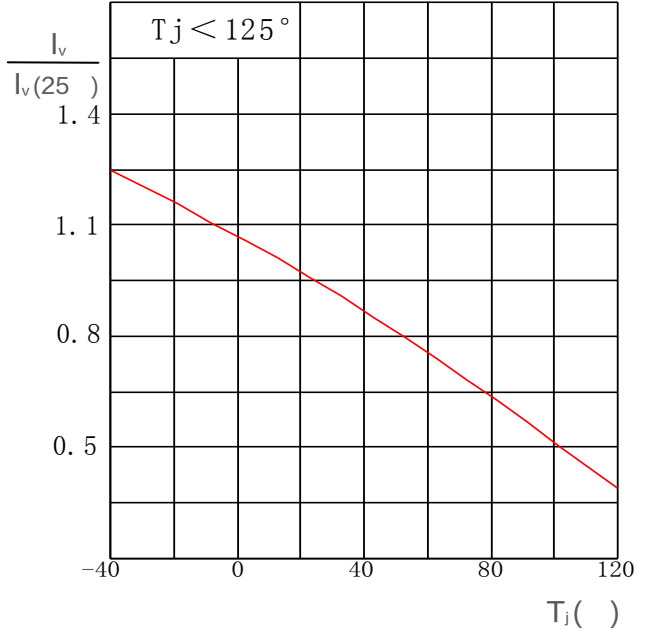

Solder Point Temperature

Ambient Temperature vs. Forward Current

$I_f = f(T_a)$

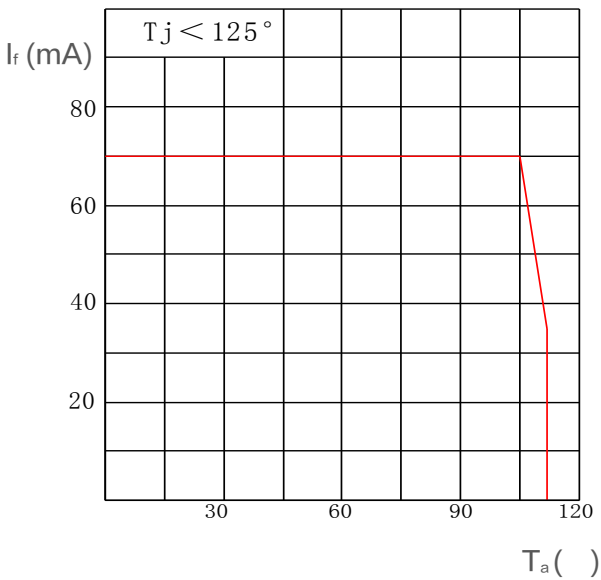

vs. Forward Current

$I_f = f(T_s)$

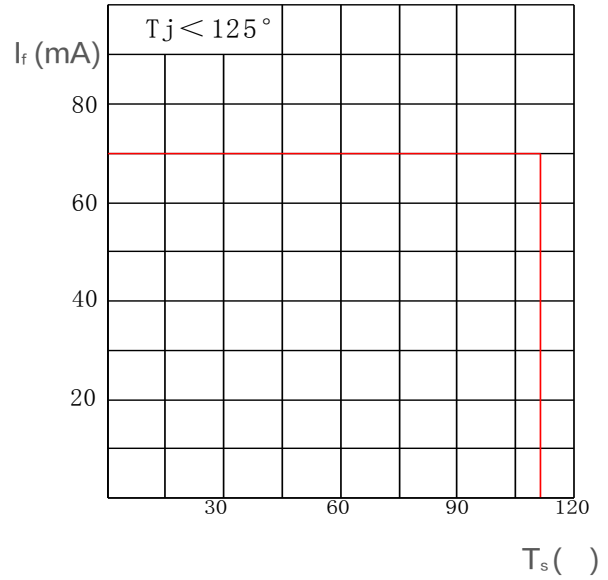

Package Outline

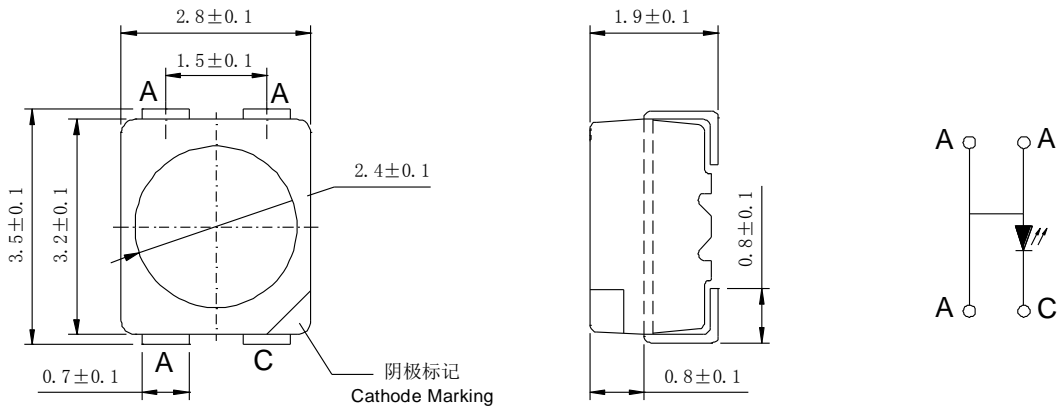

- 30mg
- Class 3B
- : 1) H₂S , 336 IEC 60068-2-43)
- 2) IEC 60068-2-60 4: 10ppb H₂S, 200ppb SO₂, 200ppb NO₂, 10ppb Cl₂)

NOTE

- Approximate Weight: 30mg
- Mark: Cathode
- Corrosion test: Class 3B
- Test conditions: 1) H₂S test , 15ppm, 336hours
(Standards IEC 60068-2-43)
- 2) Flowing
(Standards IEC 60068-2-60 test method 4: 10ppb H₂S, 200ppb SO₂, 200ppb NO₂, 10ppb Cl₂)

Recommended Solder Pad

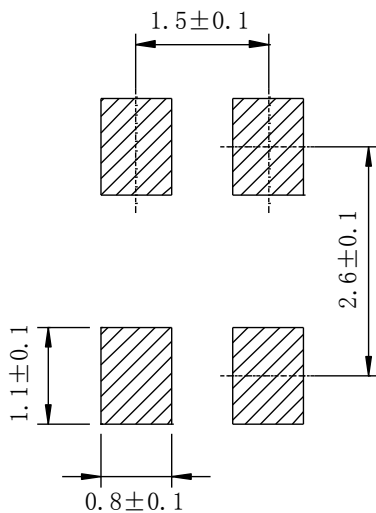

- NOTE
- Package not suitable for ultrasonic cleaning

Reflow Soldering Profile

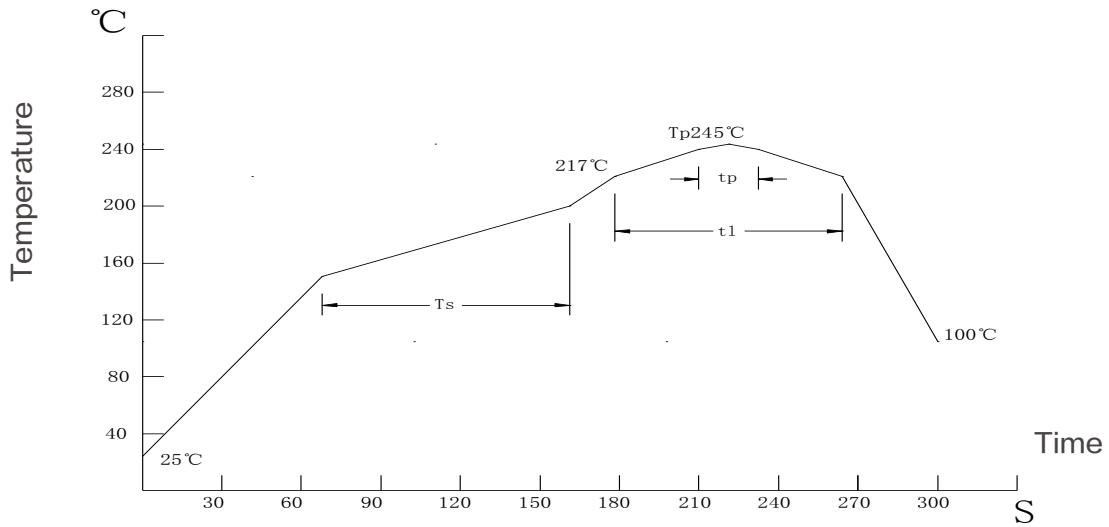

Profile Feature	Symbol	Pb-Free (SnAgCu) Assembly			Unit
		min.	rec.	max.	
Ramp-up Rate to Preheat 25 -150	-	-	2	3	/s
Time T_{smin} to T_{smax}	T_s	60	100	120	s
Ramp-up Rate to Peak T_{smax} to T_p	-	-	2	3	s
Liquidus Temperature	T_l		217		
Time above Liquidus Temperature	t_l	-	80	100	s
Peak Temperature	T_p	-	245	260	
Time within 5% of the Specified Peak Temperature	t_p	10	20	30	s
Ramp-down Rate T_p to 100	-	-	3	6	s
Time 25 to T_p	-	-	-	480	s

Tape and Reel

Tape Dimensions mm

W	P0	P1	P2	D0	E	F
8 0.1	4 0.1	4 0.1	2 0.05	1.5 0.1	1.75 0.1	3.5 0.05

Reel Dimensions mm

A	W1	W2	N	R
177.8	9.3 0.3	11.2 0.3	58.5 0.2	13.5 0.2 A

Barcode-Product-Label (BPL)

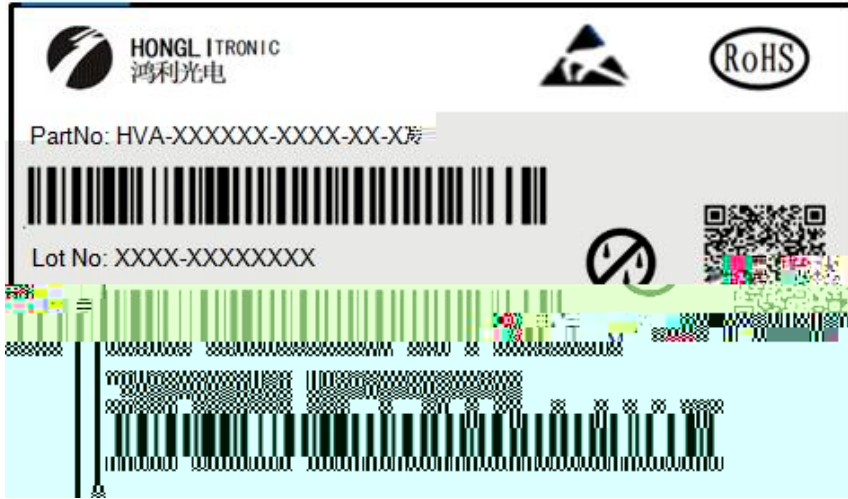

Dry Packing Process and Materials

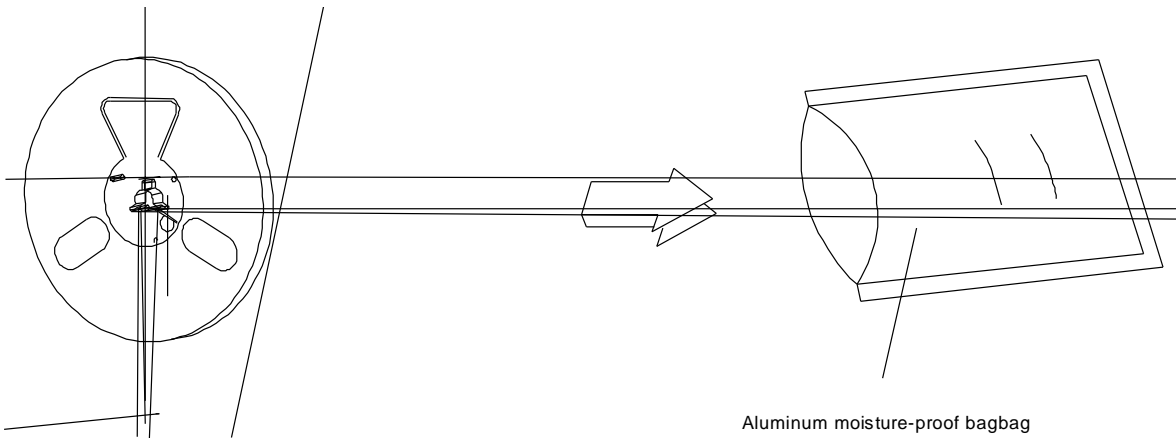

JEDEC

NOTE

Moisture-sensitive product is packed in a dry bag containing desiccant and HIC (humidity indicator card). Regarding dry pack you may find further information in the internet or JEDEC.

Transportation Packing and Materials

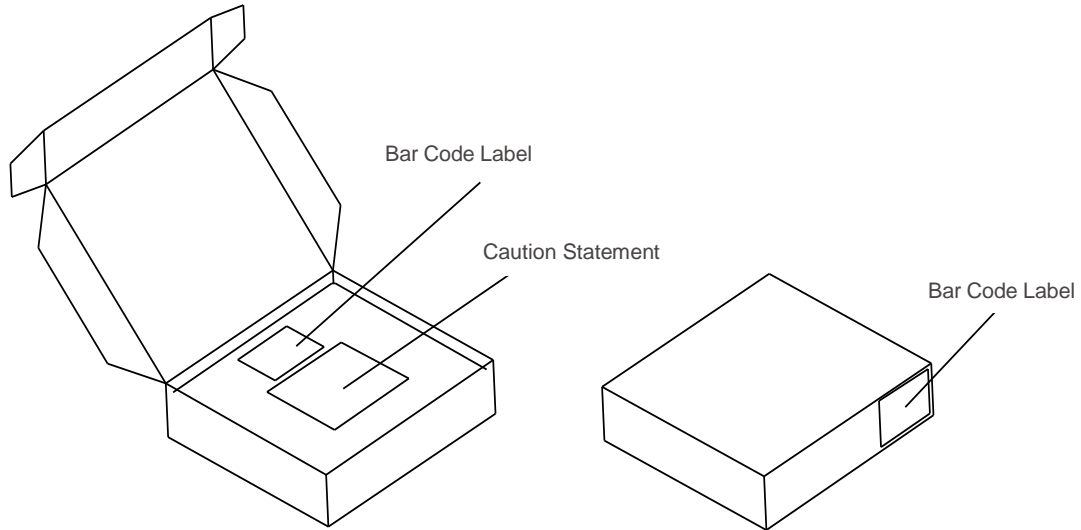

Dimensions of Transportation Box (mm)

Width	Length	Height
256 5	223 5	62 5
256 5	223 5	124 5

:			
:	,		
	8ms	0.05V	0.1V
	GUM K=3		
	25ms	0.5nm	1nm
	GUM K=3		
	25ms	8%	11%
	GUM K=3		

Glossary

Typical Values: Actual values of each product may differ from these statistical values .

Tolerance of Measure: Unless otherwise noted in drawing, tolerances are specified with +/-0.1mm.

Forward Voltage: The forward voltage is measured during a current pulse of typically 8 ms,

GUM with a coverage factor of k = 3).

Wavelength: The wavelength is measured at a current pulse of typically 25 ms,

GUM with a coverage factor of k = 3).

Brightness: Brightness values are measured during a current pulse of typically 25 ms,

with a coverage factor of k = 3).

Special Statement: The final interpretation of this specification shall be vested in Honglitronic, in the case of ambiguity, the Chinese version shall prevail.