



---

---

---

---

		 <i>Handwritten signature</i>	

.

.

.

.

/





**ATTENTION**  
OBSERVE PRECAUTIONS  
FOR HANDLING  
ELECTROSTATIC  
DISCHARGE  
SENSITIVE  
DEVICES



- 
- 
- 
- 
- 

)便携式照明

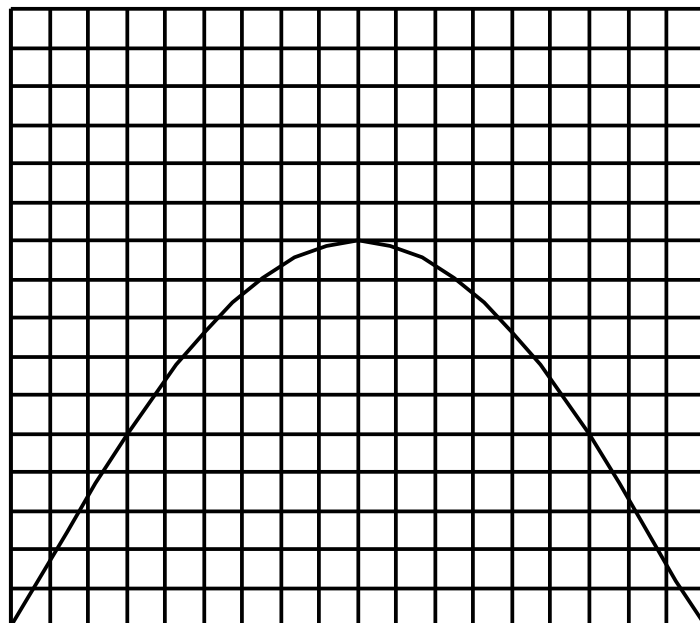
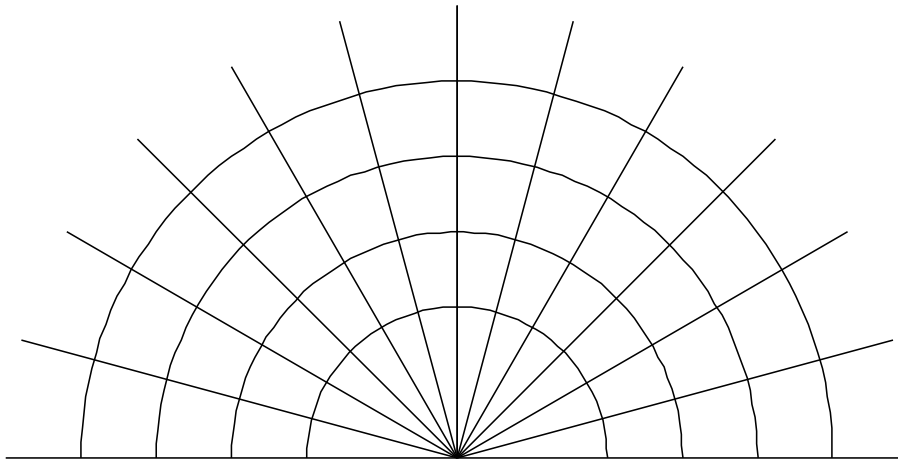

			°
			degrees
		°	°

:

□

□

°C,

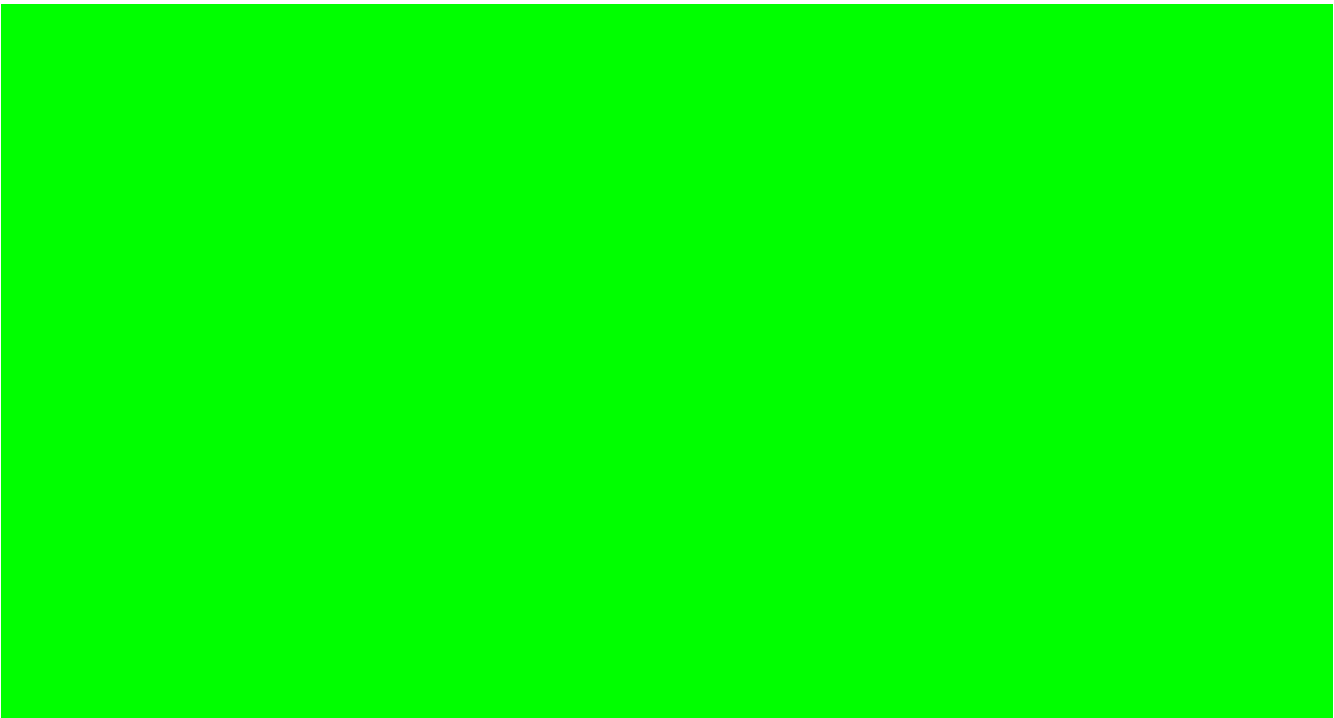

:

Notes

2.

$T_a=25^{\circ}\text{C}$

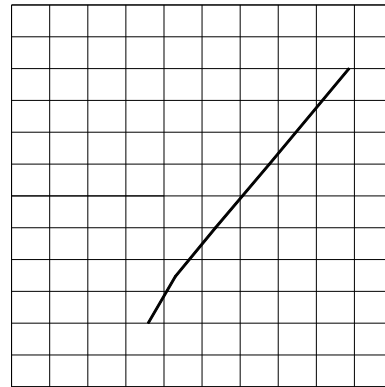
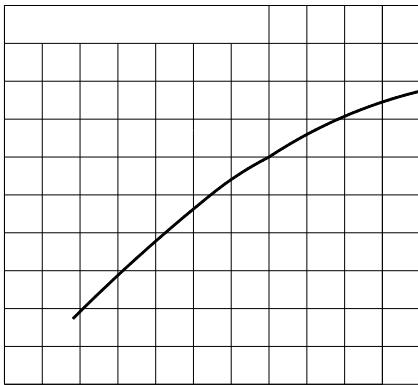

**Solder Temperature vs. Relative Luminous Flux**

IF=350mA

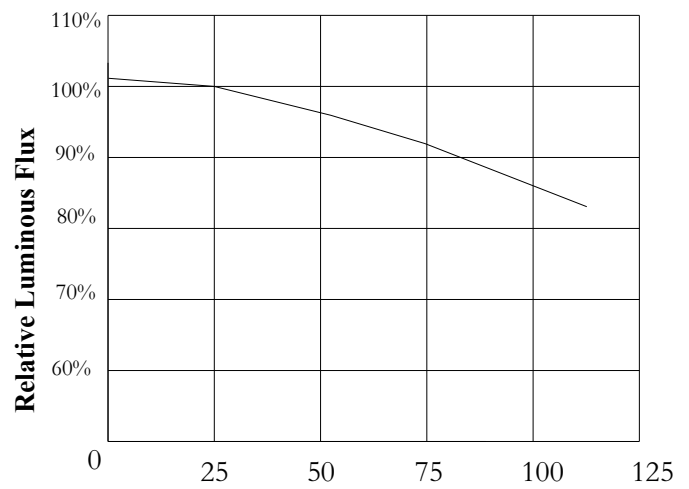
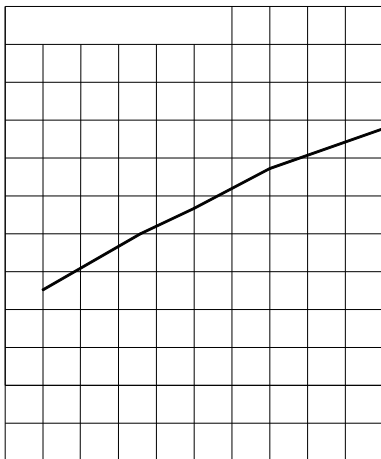

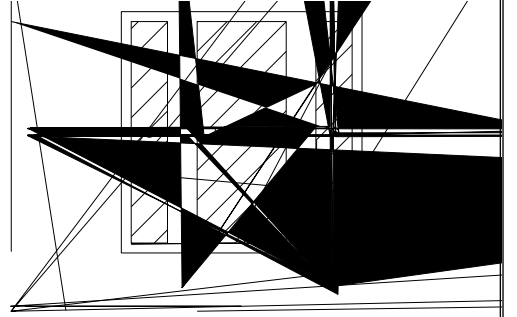
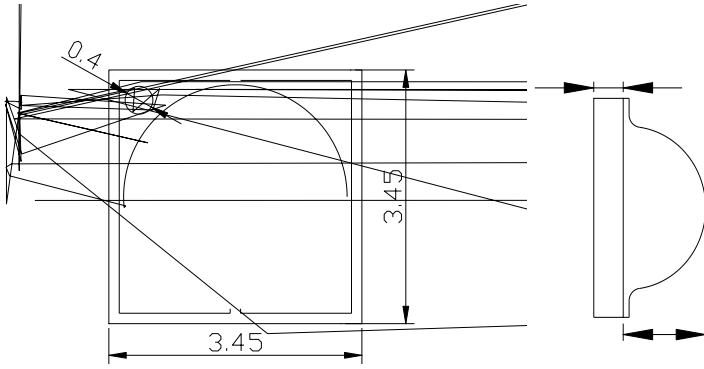

±

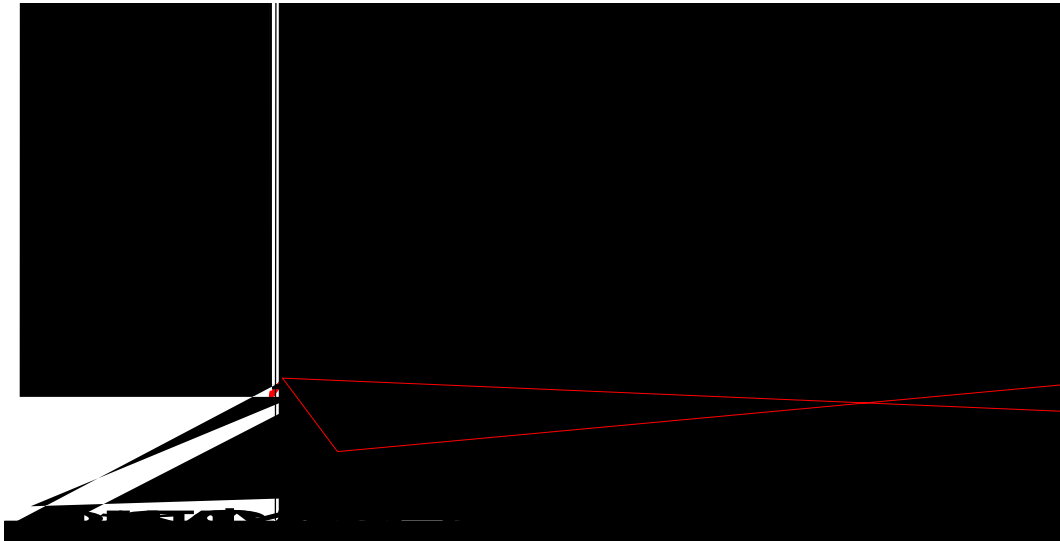

:



Φ

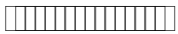

**HONGLITRONIC**  
鸿利光电

**RoHS**

**TYPE:** \_\_\_\_\_ **QTY:** \_\_\_\_\_

**VF:** \_\_\_\_\_ **XY:** \_\_\_\_\_ **ΦV:** \_\_\_\_\_

**IF:** \_\_\_\_\_ **TC:** \_\_\_\_\_

**DATE:** \_\_\_\_\_ **LOT.NO:** \_\_\_\_\_

**(1) Reel package ( 1000 pcs/reel)**

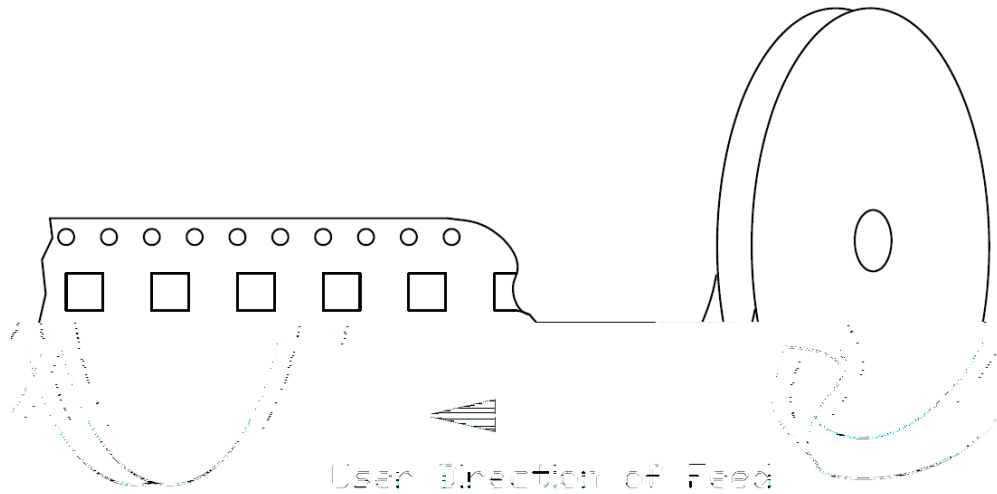
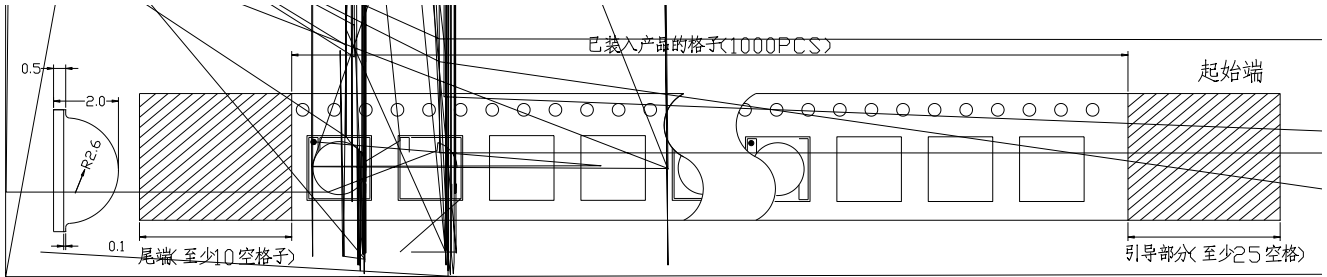

**(2) Moisture resistant packaging**

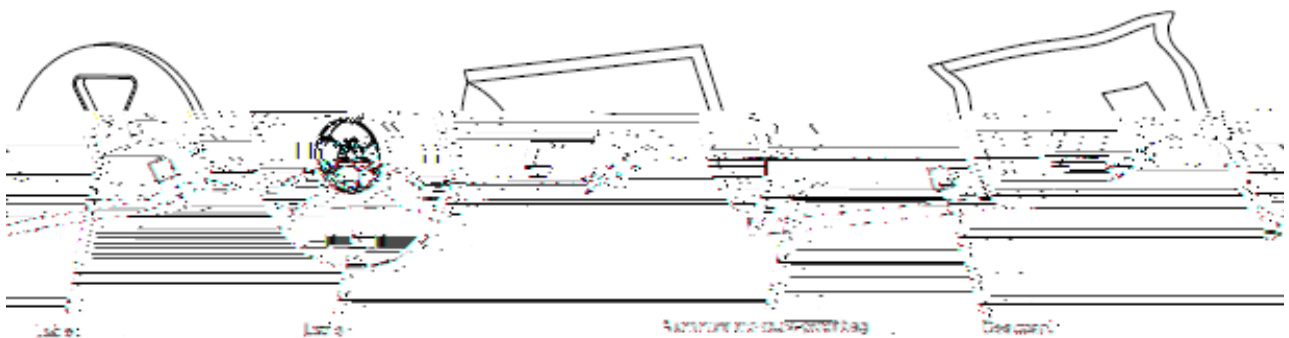

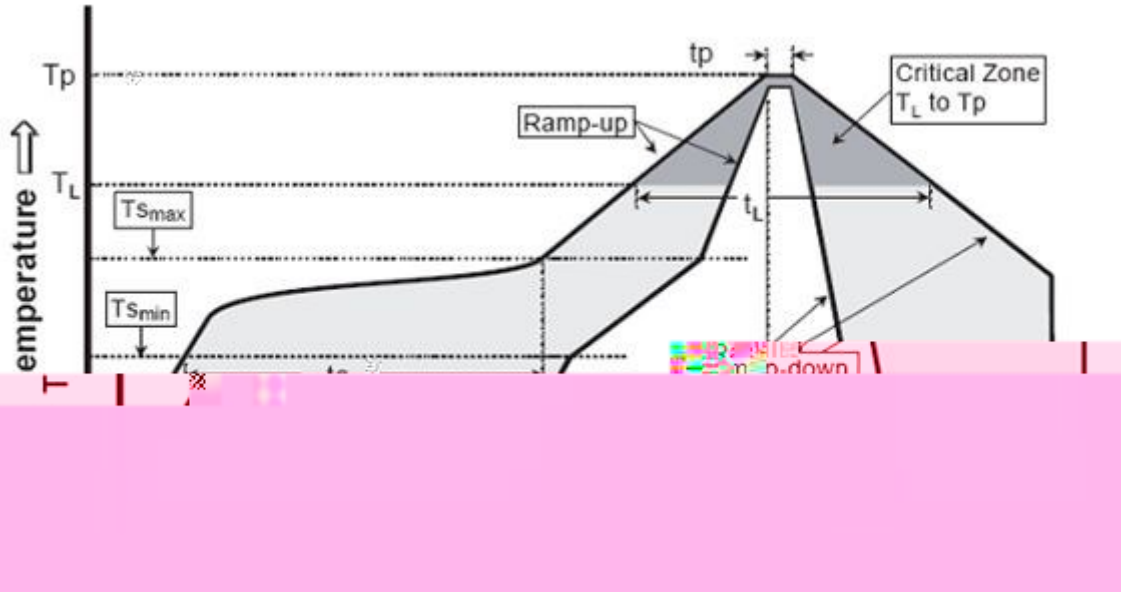



Note:

□□□□

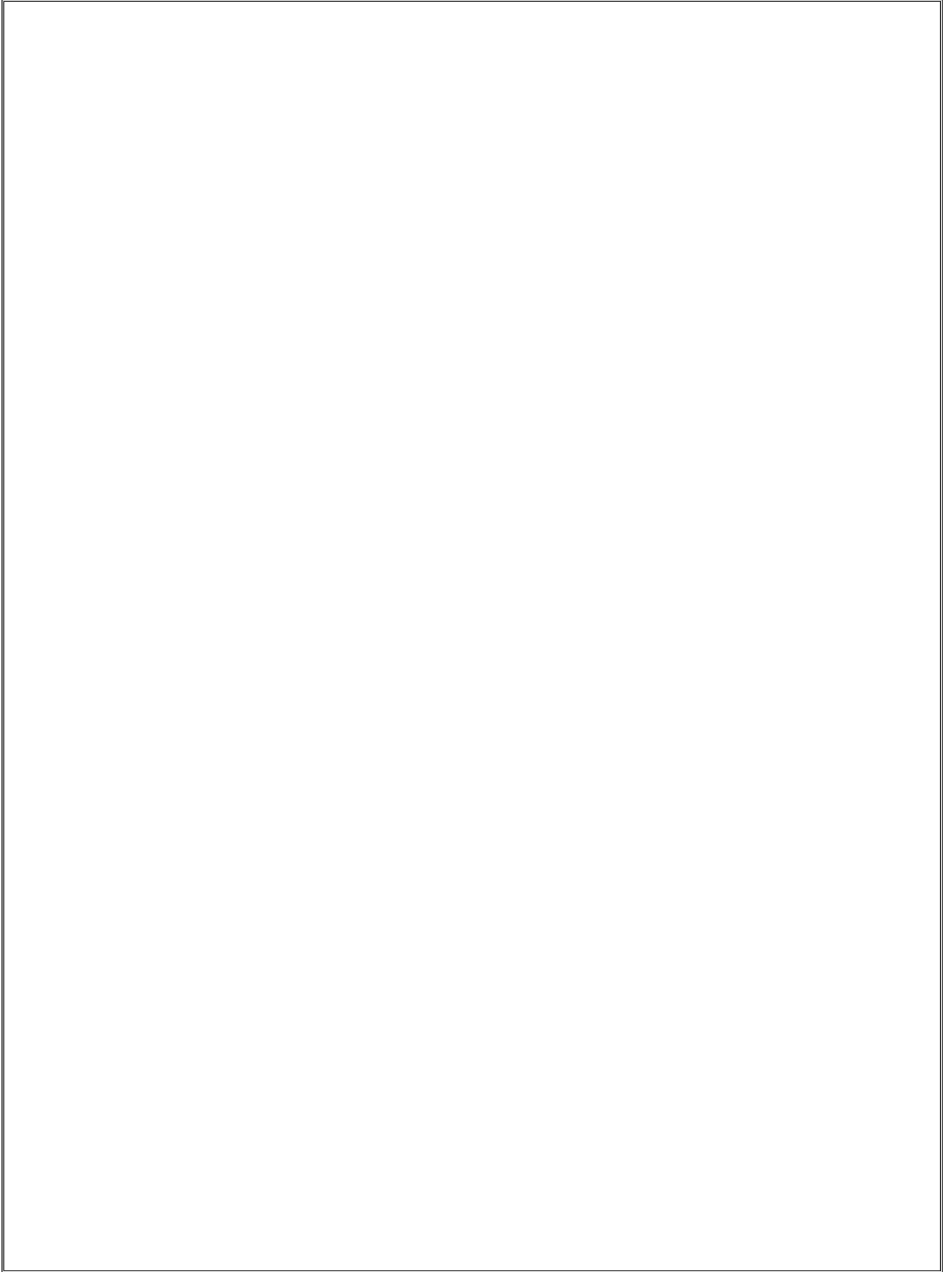
□□□□

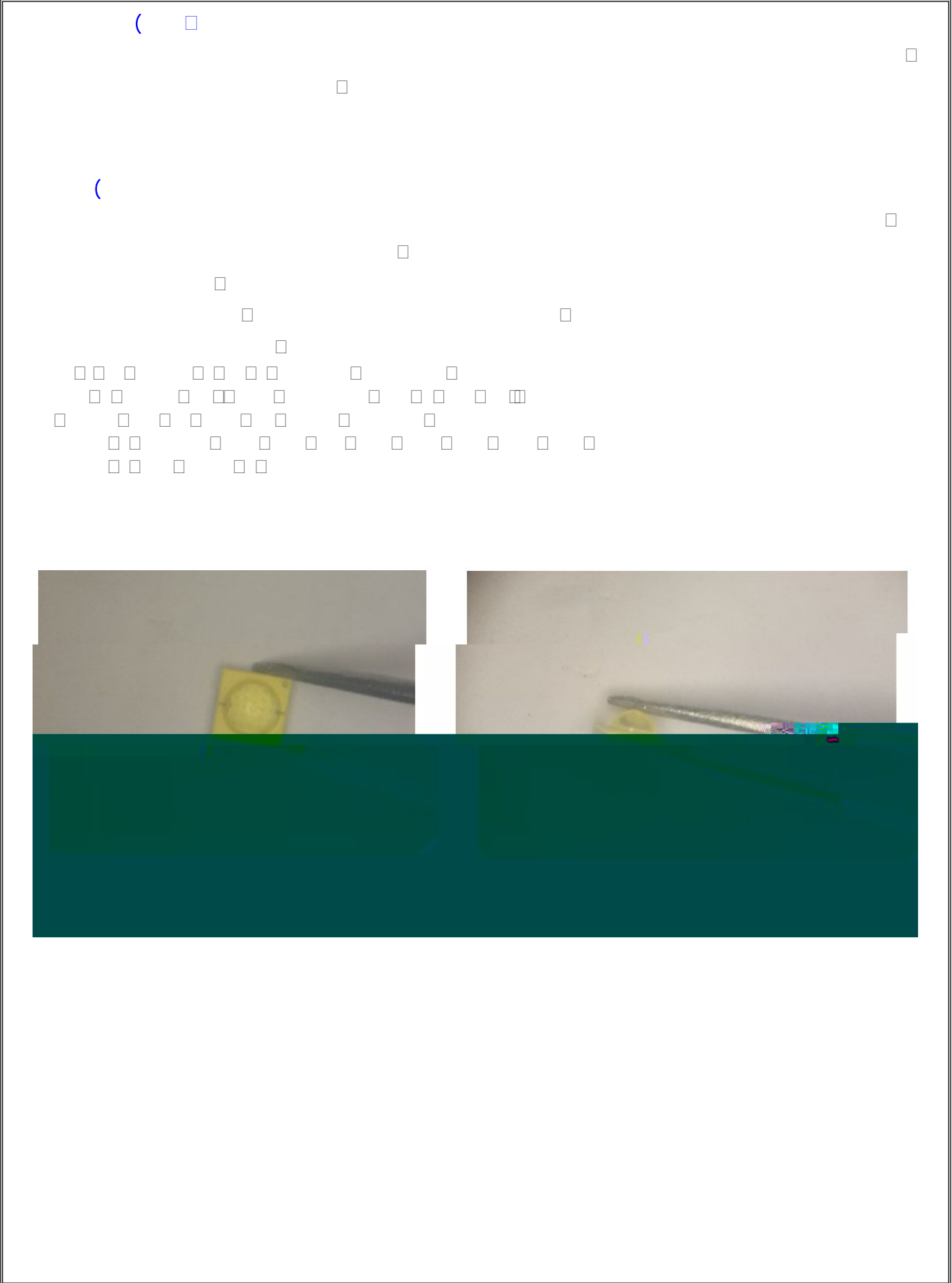

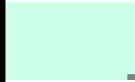

—

—