





Client approval		Hongli ZhiHui approval	
			
		2017. 07. 01	

Adr NO.1,Xianke Yi Road,Huadong Town., Huadu District, Guangzhou, China

Tel/ 020-86733333 Fax/ 020-86733883 86733938 86733265

Web/ www.honglitronic.com

- .1.
- 2.
- 3.



Catalog

.	3
.	3
.	4
4.	4
.	5-6
	7
/	8
	9
	9
	10
	11
	12
	13-14



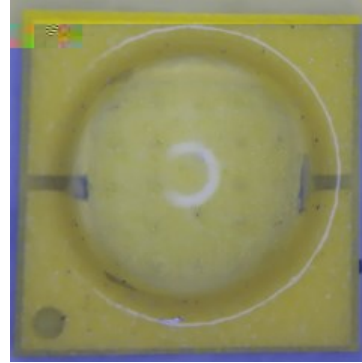

ATTENTION
OBSERVE PRECAUTIONS
FOR HANDLING
ELECTROSTATIC
DISCHARGE
SENSITIVE
DEVICES



100ns

RoHS



-
-
-
-
-

)便携式照明

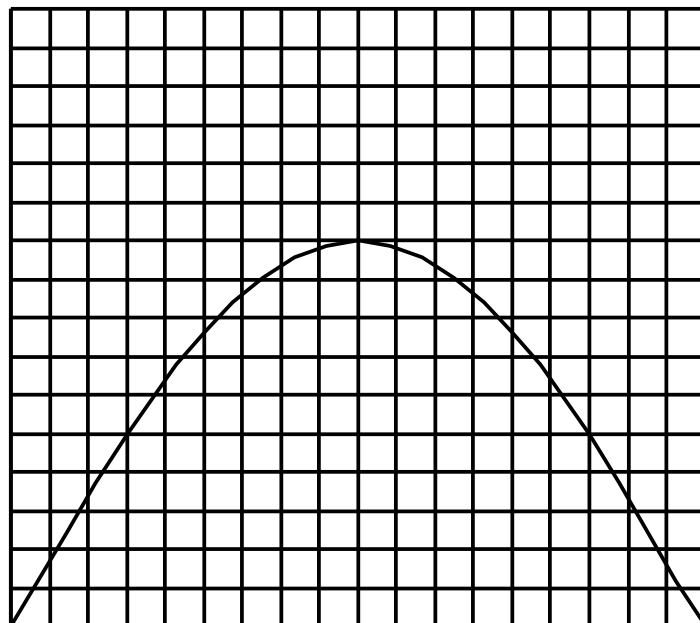
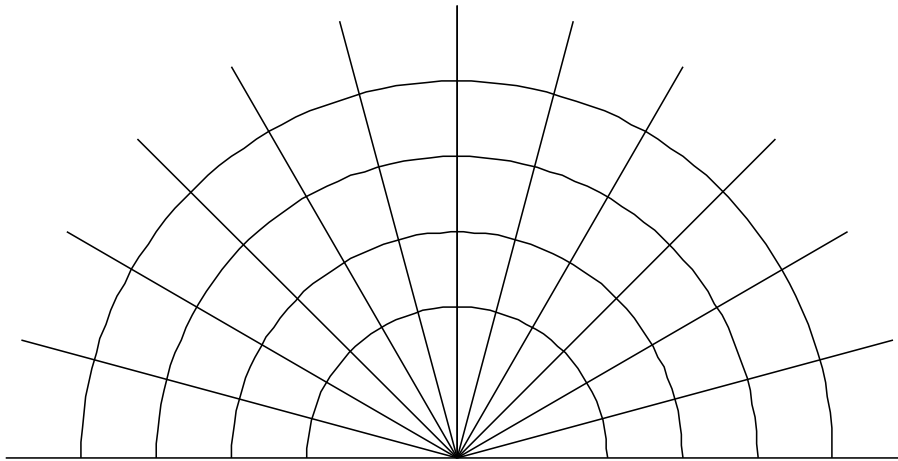



			°
			degrees
		°	°

:

□□

□□□

°C,



:





	2200K	2725K	3045K	3985K	5028K	5665K
X, Y	0.507 0.4148	0.4582 0.4098	0.4338 0.403	0.3818 0.3797	0.3447 0.3553	0.329, 0.3417

Notes

2.



$T_a=25^{\circ}\text{C}$

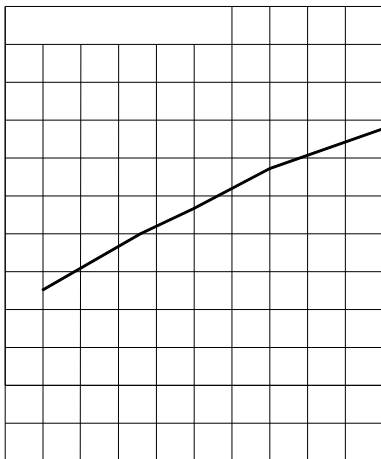
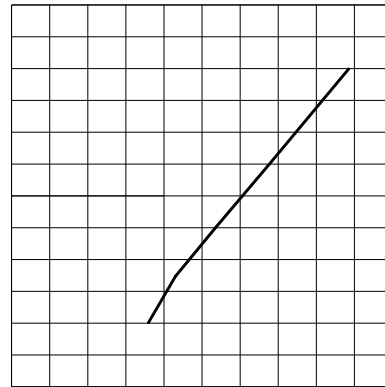
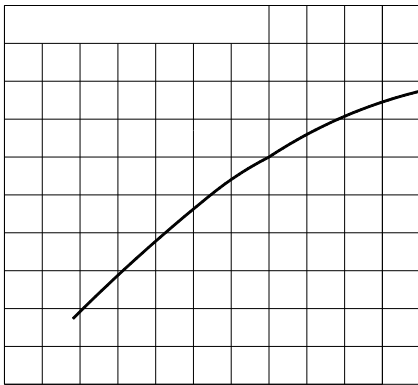

Solder Temperature vs. Relative Luminous Flux

IF=350mA

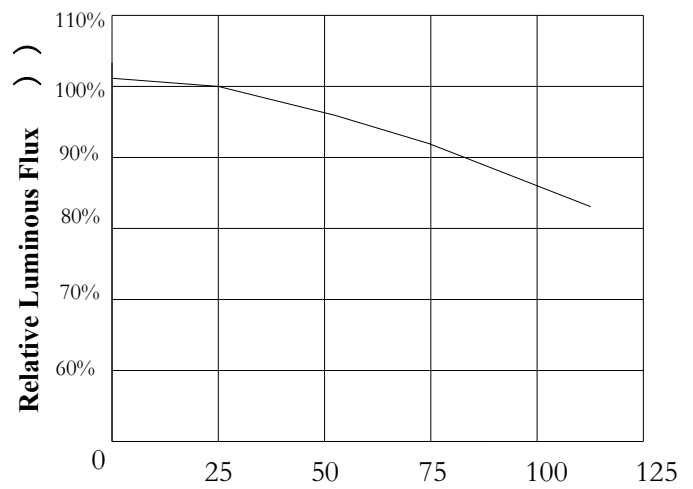



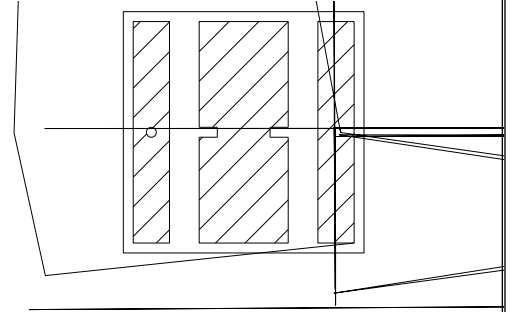
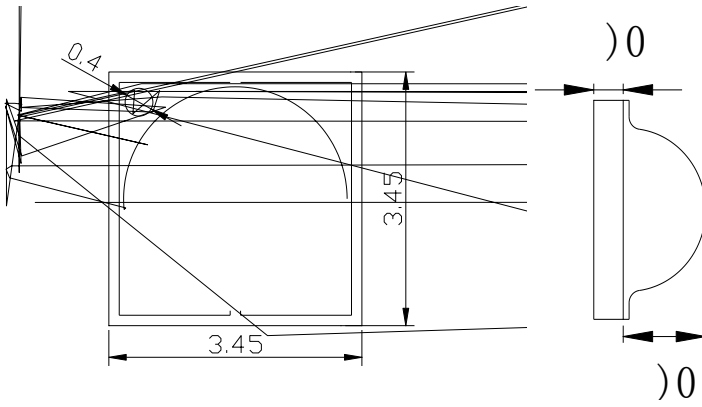

±

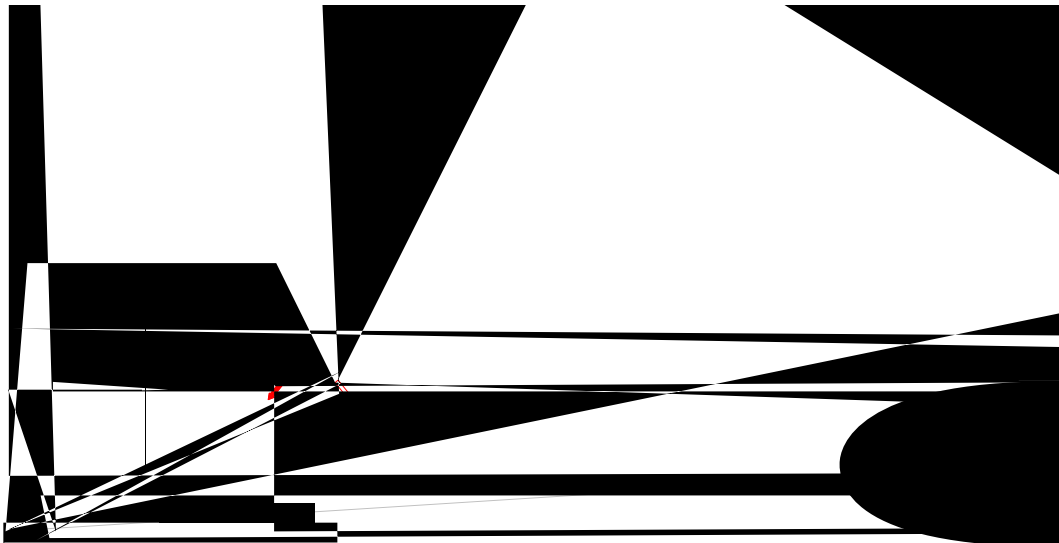



HONGLITRONIC
鸿利光电

:



Φ

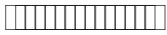

HONGLITRONIC
鸿利光电

RoHS

TYPE:

QTY:

VF:

XY:

φV:

IF:

TC:

DATE:

LOT.NO:



(1) Reel package (1000 pcs/reel)

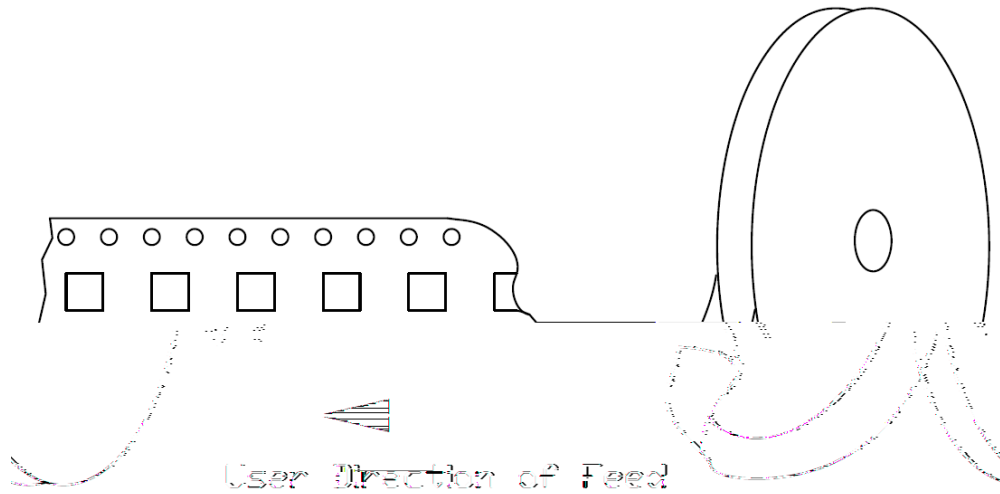
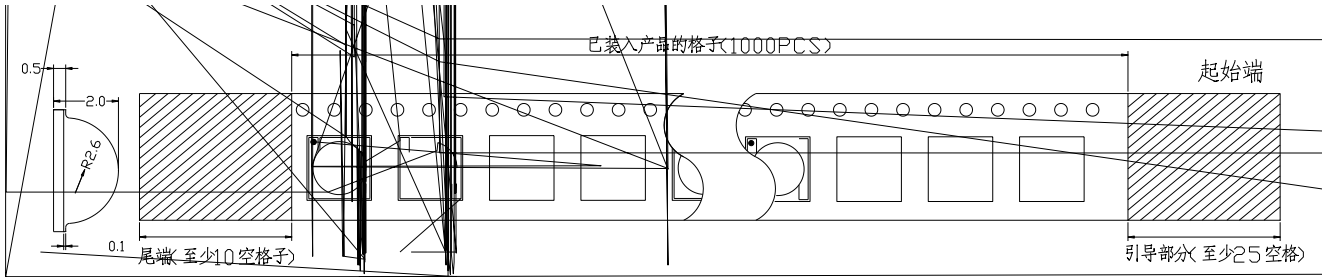

(2) Moisture resistant packaging

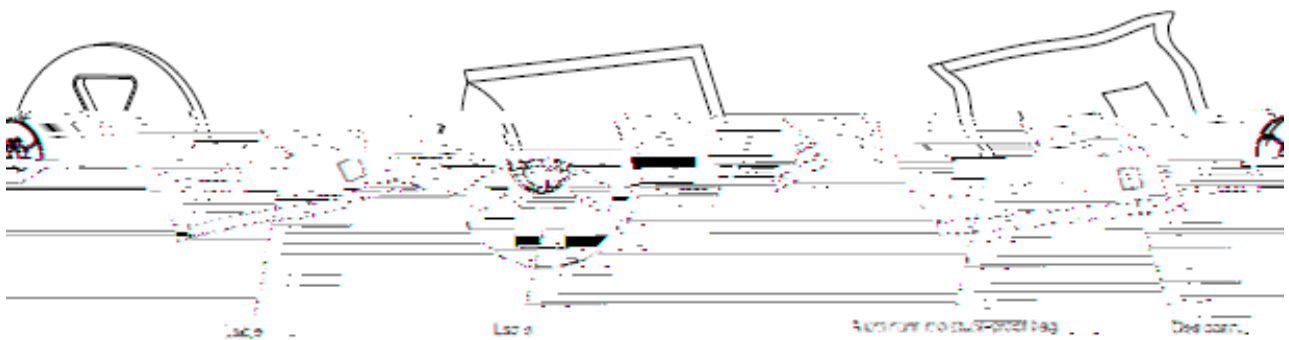



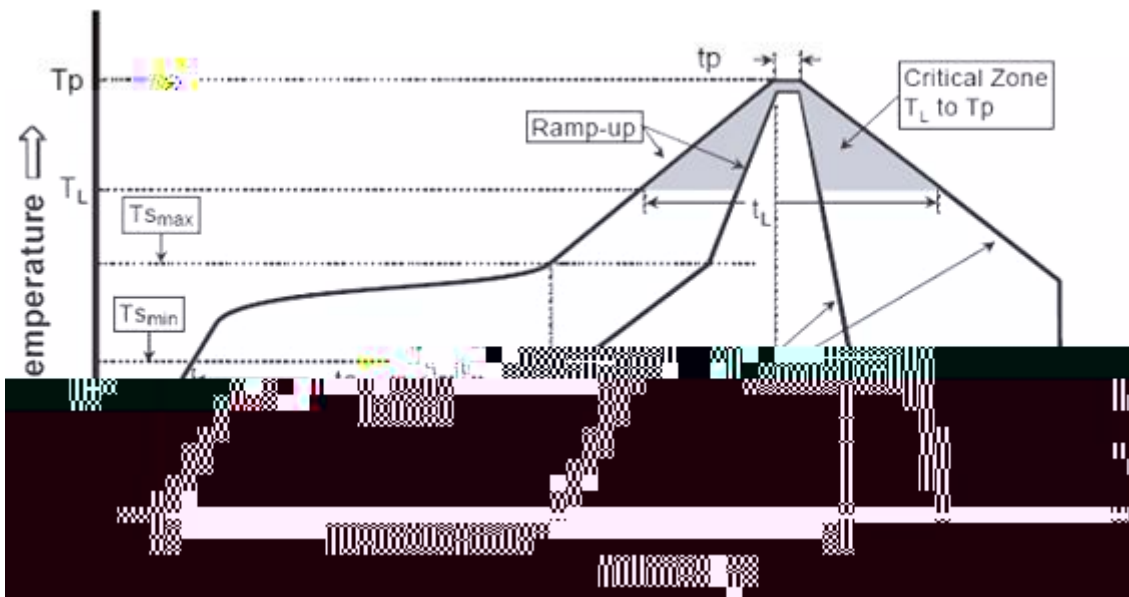

	°C	°C
	°C	°C
	°C	°C
	°C	°C
°C		
	°C	°C
°C		

Note:

□□□□

□□□□

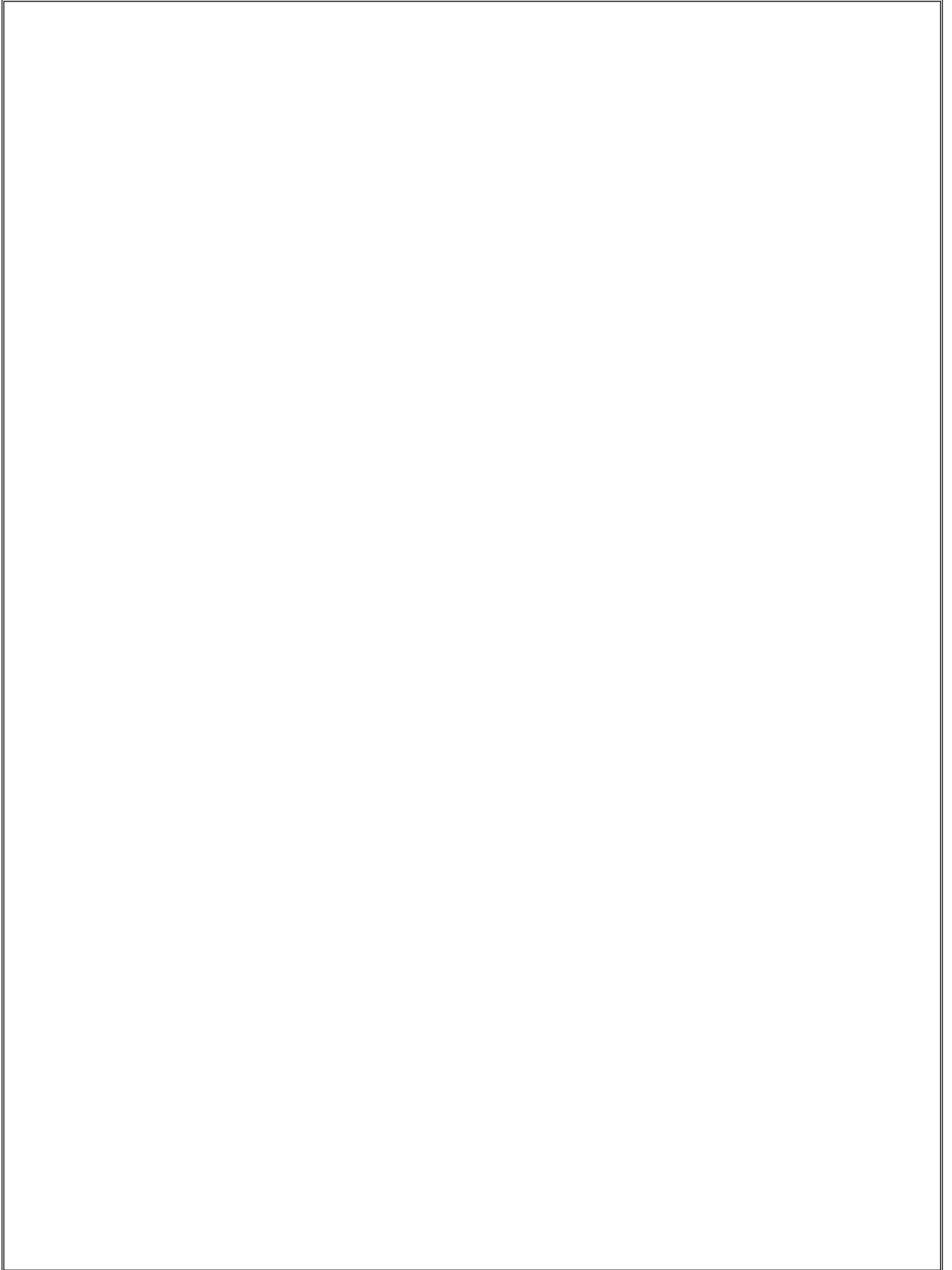



1			2017. 07. 01	A/0
2		700mA	2018. 05. 08	A/0
3		2000K-2400K	2019. 01. 10	A/0
4				
5				
6				
7				
8				
9				
10				
11				